

Colmena Langstroth

Adjunto varios diagramas que demuestran las medidas representativas de los diferentes componentes estructurales de la colmena basada en el diseño Langstroth. La madera generalmente utilizada es el Pino Blanco o el Cedro, siendo el Cedro más atractivo para uso en el trópico. Pero se puede utilizar cualquier madera que no expanda y contraiga mucho como resultado de variaciones diarias y estacionales en temperatura y humedad. La idea principal detrás de utilizar consistentemente el mismo diseño es que los componentes sean intercambiables.

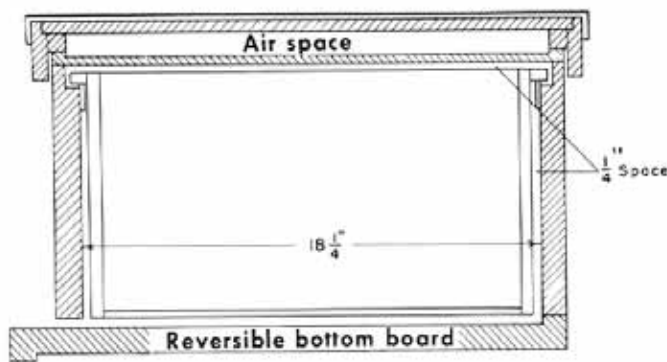

CROSS SECTION OF HIVE BODY AND FRAME

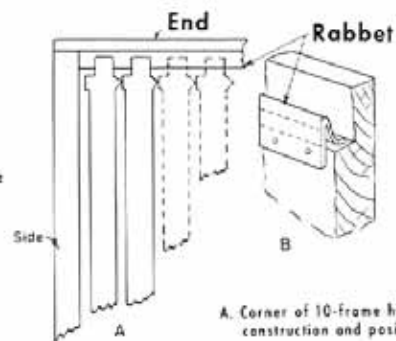

A. Corner of 10-frame hive body, showing construction and position of frames

B. Part of end of hive body, showing rabet, which should be made of tin or galvanized iron.

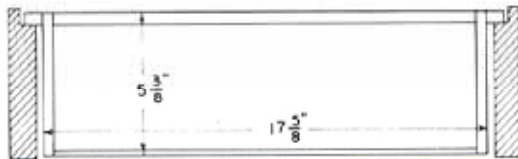

CROSS SECTION OF SHALLOW SUPER

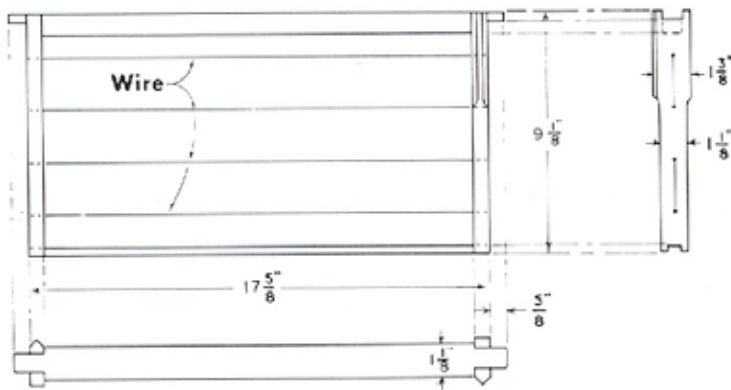
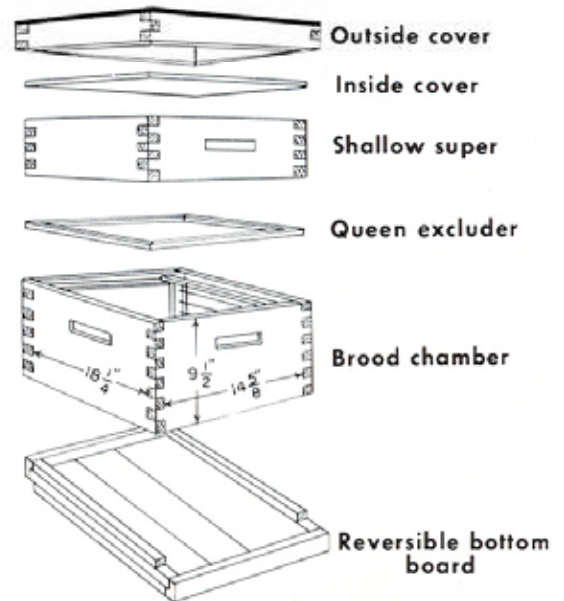

SIDE, END, AND TOP ELEVATION OF FRAME

Basic Hive Parts

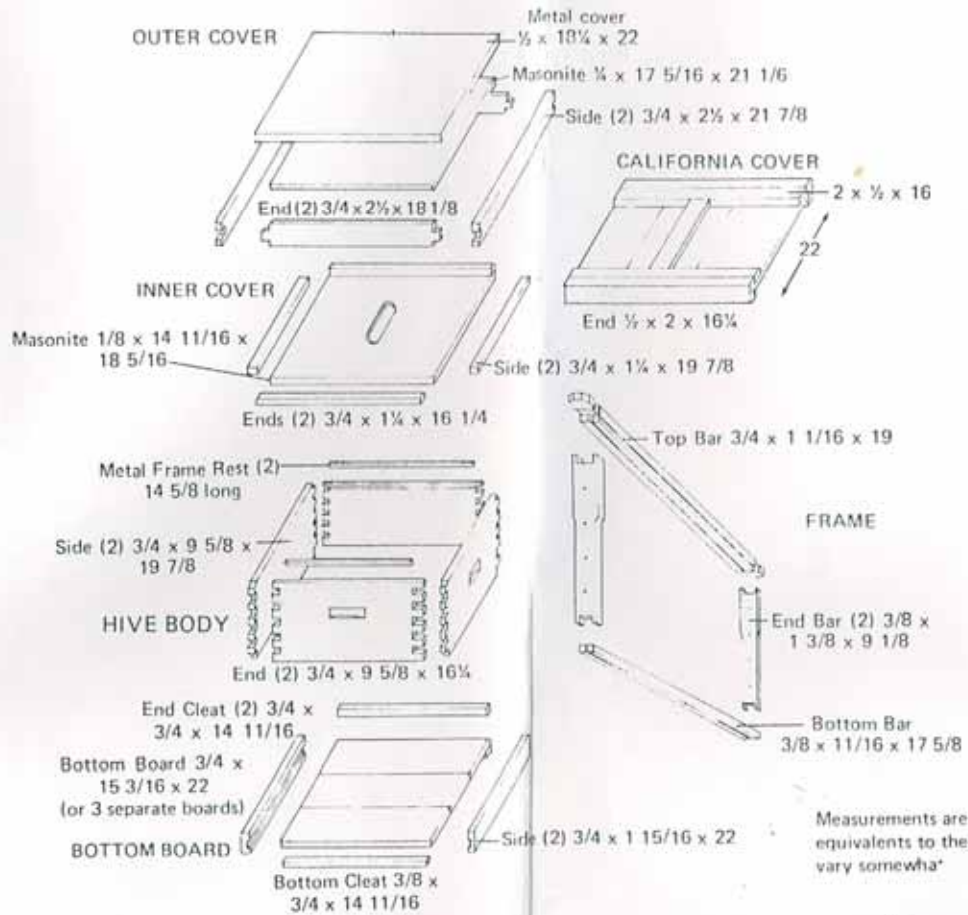

Measurements are in inches. Metric equivalents to these hive dimensions vary somewhat.

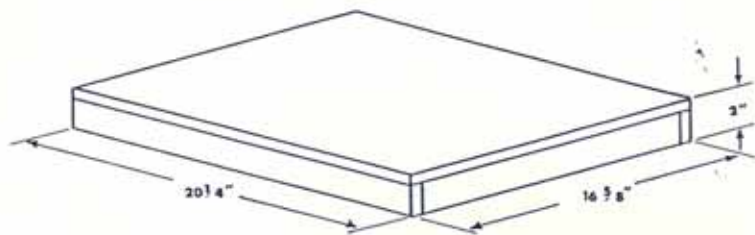

OUTER COVER MATERIAL

- 3 PIECES 7 1/4" x 3/4" x 18" (TOP)
- 2 PIECES 21 1/4" x 3/4" x 2" (SIDES)
- 2 PIECES 16 1/4" x 3/4" x 2" (ENDS)

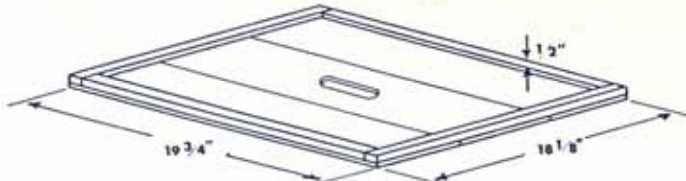

INNER COVER MATERIAL

- 2 PIECES 5/2" x 3/4" x 16 1/4"
- 2 PIECES 5/2" x 3/4" x 18 1/4"
- 2 PIECES 6" x 3/4" x 19 1/4"
- 1 PIECE 4 1/4" x 3/4" x 19 1/4"

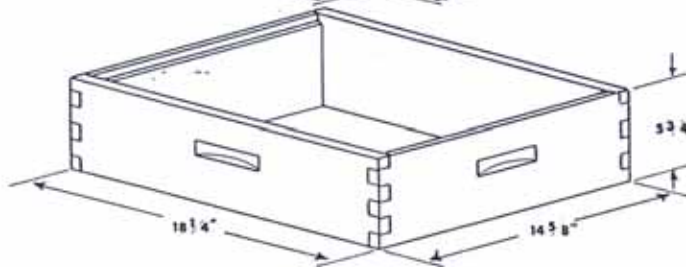

SHALLOW SUPER MATERIAL

- 2 PIECES 19 1/4" x 3/4" x 5 1/4" (SIDES)
- 2 PIECES 14 5/8" x 3/4" x 5 1/4" (ENDS)



QUEEN EXCLUDER

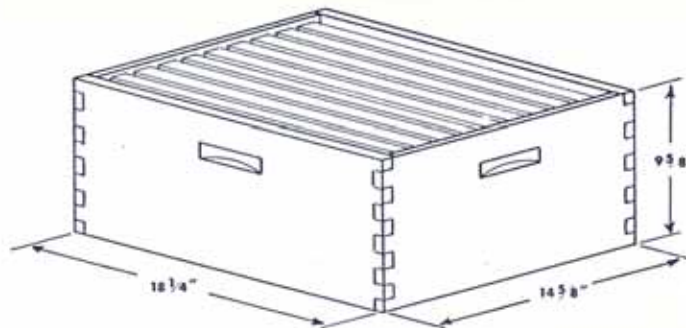

HIVE BODY MATERIAL

- 2 PIECES 19 1/4" x 3/4" x 9 5/8" (SIDES)
- 2 PIECES 14 5/8" x 3/4" x 9 5/8" (ENDS)

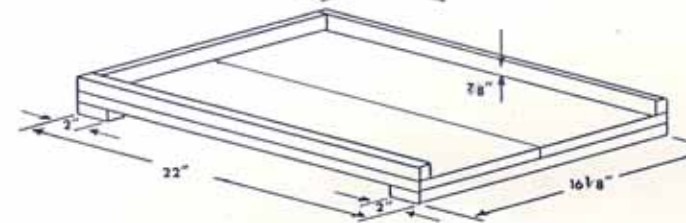

BOTTOM BOARD MATERIAL

- 2 PIECES 8-1/16" x 3/4" x 22" (FLOOR)
- 2 PIECES 3/4" x 3/4" x 22" (SIDES)
- 1 PIECE 3/4" x 3/4" x 14 1/4" (END)
- 2 PIECES 2" x 3/4" x 16 1/4" (CLEATS)

Figure 1. Equipment and dimensions for a 10-frame standard Langstroth hive.